

Description

Microcontroller operated Flow Meter to monitor and display flow rates and temperature. Once correctly adjusted it can also be used for mass flow measurements. Factory preset for air and water.

The RS232 interface allows configuration, operation and data logging by means of a PC software.

Features

- Menu driven (keypads)
- LC display (2 x 16 digits) can show:
 - actual flow velocity, volume flow rate, temperature
 - directions for parameter assignment, configuration, diagnostics and error correction;
 - peak values indication
- Two scalable analogue outputs
- Minimum/maximum memory of flow velocity and temperature
- Two freely selectable limit contacts
- Volume flow dependent pulse output
- Totalizer (with external reset), power fail-safe
- display illumination
- RS232 interface allows configuration, operation and data logging by means of a PC software

Ordering information

Type	
FC100	Flow Meter in rail mounted housing
FC100-FH	Flow Meter in surface mounted housing
Input voltage	
U1	DC 10 ... 40 V
Signal outputs	
R2	2 relay outputs (2 limit values)
T4	4 transistor outputs (2 limit values + 2 status or 2 limit values + 1 status + 1 pulse output)
Analogue outputs	
V1	0/1-5 Volt
V2	0/2-10 Volt
C1	0/4-20 mA (self-powered, galvanically isolated)
Serial interface	
K1	RS232 (with PC-Software)
FC100 - U1 R2 V1 K1	ordering example



FC100
rail mounted housing surface mounted housing

Dimensions

FC100 (rail mounted housing)

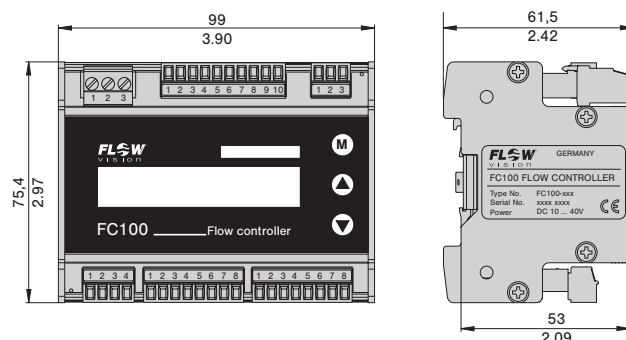

FC100-FH (surface mounted housing)

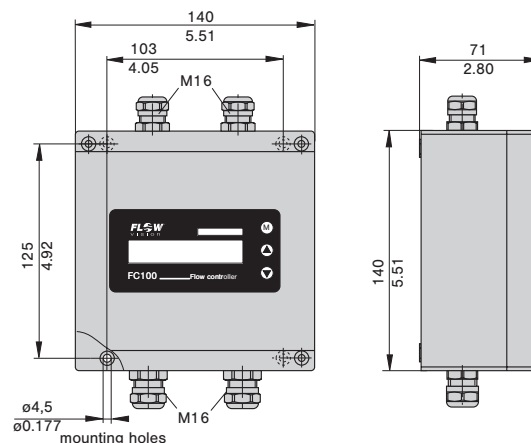

This is a metric design and millimeter dimensions take precedence (mm / inch)

TECHNICAL DATA

Flow Meter FC100		with CST/CSF calorimetric monitoring heads
General data		
Suitable for	gases, liquids (oil etc.)	
Measuring functions	flow velocity, volume flow rate, temperature	
Display	2 x 16-digit LC display (illuminated)	
Configuration by	keypads or PC software	
Serial interface	RS232, PC-Software runs on Windows® XP/Windows Vista®/Windows® 7	
Ambient temperature range (electronic control unit)	+5 °C ... +50 °C/+41 °F ... +122 °F	
Electrical data		
Supply voltage	DC 10 ... 40 V	
Power consumption	DC 10 V: 650 mA; DC 24 V: 240 mA; DC 40 V: 150 mA	
Analogue outputs	flow and temperature	0/4-20 mA or 0/2-10 V or 0/1-5 V
Signal outputs	2 relay outputs (2 limit values)	2 SPDT contacts AC/DC 50 V/1 A/50 W
	4 transistor outputs (2 limit values + 2 status, or 2 limits values + 1 status + 1 pulse output)	open collector outputs DC 36 V/150 mA/1,5 W
Flow measurement		
Measuring range (display range)	water	0,05 ... 3 m/s (0 ... 4 m/s)/0.164 ... 9.84 fps (0 ... 13.1 fps)
	air	0,1 ... 20 m/s (0 ... 100 m/s)/0.328 ... 65.6 fps (0 ... 328 fps)
Accuracy	water	see failure diagram
	air	see failure diagram
Repeatability ⁽¹⁾	water	≤ 1 % of measured value (5% ... 100% of measuring range final value)
	air	≤ 1 % of measured value (5% ... 100% of measuring range final value)
Temperature drift	water	± 0,05 %/°C of measuring range final value/ ± 0,09 %/°F of measuring range final value
	air	± 0,05 %/°C of measuring range final value/ ± 0,09 %/°F of measuring range final value
Response delay	water ⁽²⁾	2,5 s
	air ⁽³⁾	3 s
Temperature measurement	measuring range	-40 °C ... +130 °C/-40 °F ... +266 °F
	accuracy	± 1 % of measuring range
Mechanical data (electronic control unit)		
Degree of protection	rail mounted	IP20
	surface mounted	IP65
Materials	rail mounted	Aluminium, display: polyester foil
	surface mounted	Aluminium/acrylic
Housing dimensions (LxWxH)	see dimensions (previous page)	
Weight	rail mounted	365 g/0.805 lb
	surface mounted	1200 g/2.65 lb
Cables	voltage supply	3x0,75 mm ² /3x1.16·10 ⁻³ in. ² (AWG 18)
	to monitoring head	LifYCY 4x2x0,2 mm ² /4x2x0.31·10 ⁻³ in. ² (AWG 24)
	analogue outputs	2 x LifYCY 2x0,25 mm ² /2x0.388·10 ⁻³ in. ² (AWG 24)
	limit value outputs	2 x LifYCY 3x0,38 mm ² /3x0.589·10 ⁻³ in. ² (AWG 22)
	Max. cable length to monitoring head	200 m/656 ft
⁽¹⁾ Of the set value, at constant temperature and flow conditions, and stable thermal conductivity. ⁽²⁾ Delay with the switch point set to 1 m/s / 3.28 fps and the flow at 2 m/s / 6.56 fps, after a sudden complete stop. ⁽³⁾ Delay with the switch point set to 10 m/s / 32.8 fps and the flow at 20 m/s / 65.6 fps, after a sudden complete stop. Windows and Windows Vista are either registered trademarks or trademarks of Microsoft Corporation in the United States and/or other countries.		

Block diagram

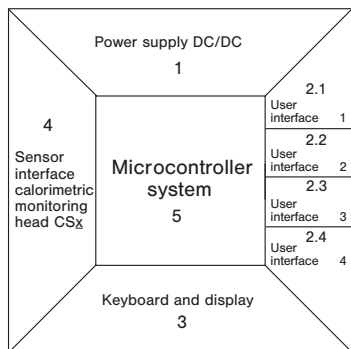

- 1 Input voltage: DC 10 ... 40 V
- 2.1 User interface 1: relay outputs: 2 limit values
transistor outputs: 2 limit values + 1 error indication + 1 busy signal or pulse output (software selected)
- 2.2 User interface 2: analogue outputs: temperature and flow current or voltage
- 2.3 User interface 3: RS232 interface
- 2.4 User interface 4: totalizer reset: edge controlled potential free, normally open contact or voltage pulse DC10 ... 40 V
- 3 Keyboard/Display: keypads
LC display
2 x 16 digits
backlight (can be switched off)
- 4 Sensor interface: calorimetric monitoring head type CSx
- 5 Controller system: signal processing
I/O - controlling
monitoring
parameter memory
communication

Connection diagram

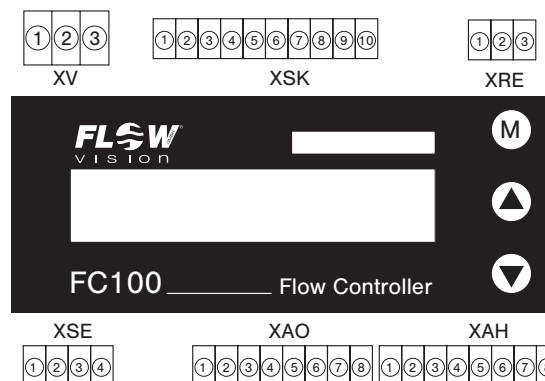

- XV - power supply
- XSK - calorimetric monitoring head
- XRE - totalizer reset
- XSE - RS232 communication interface
- XAO - analogue outputs
- XAH - signal outputs

Failure diagram for water

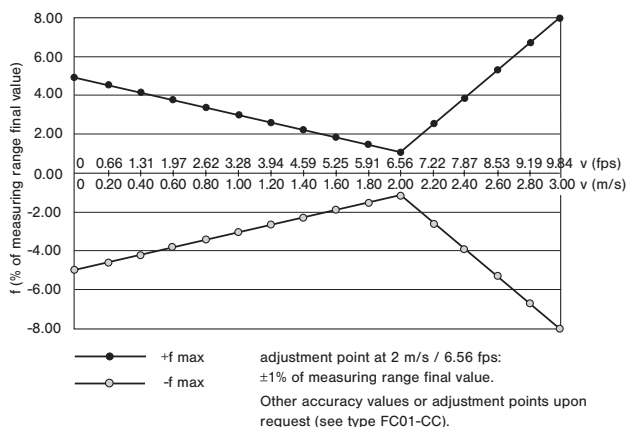

Failure diagram for air

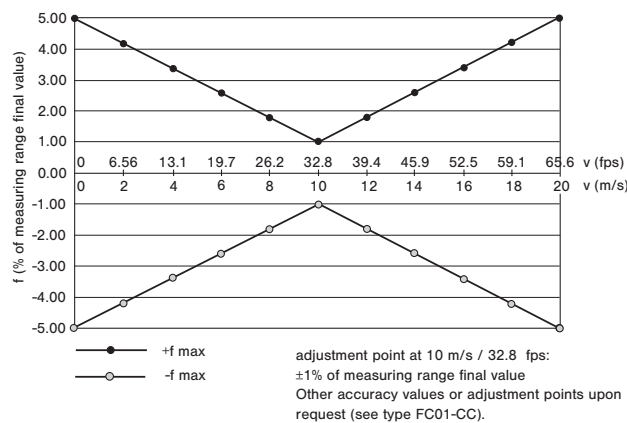

Connection diagrams

FC100 with relay outputs

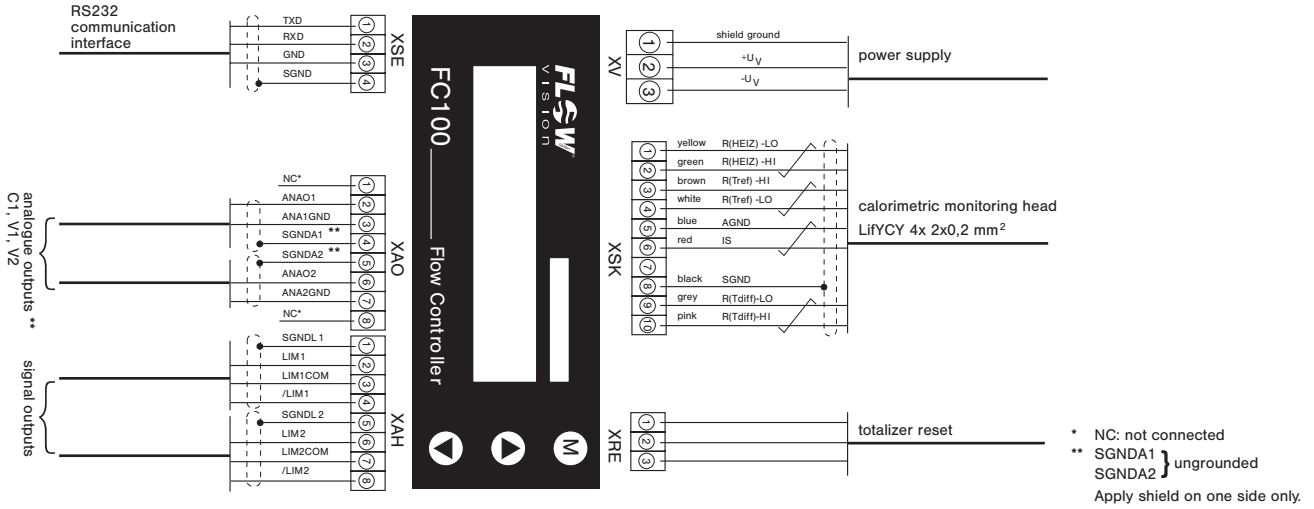

FC100 with transistor outputs

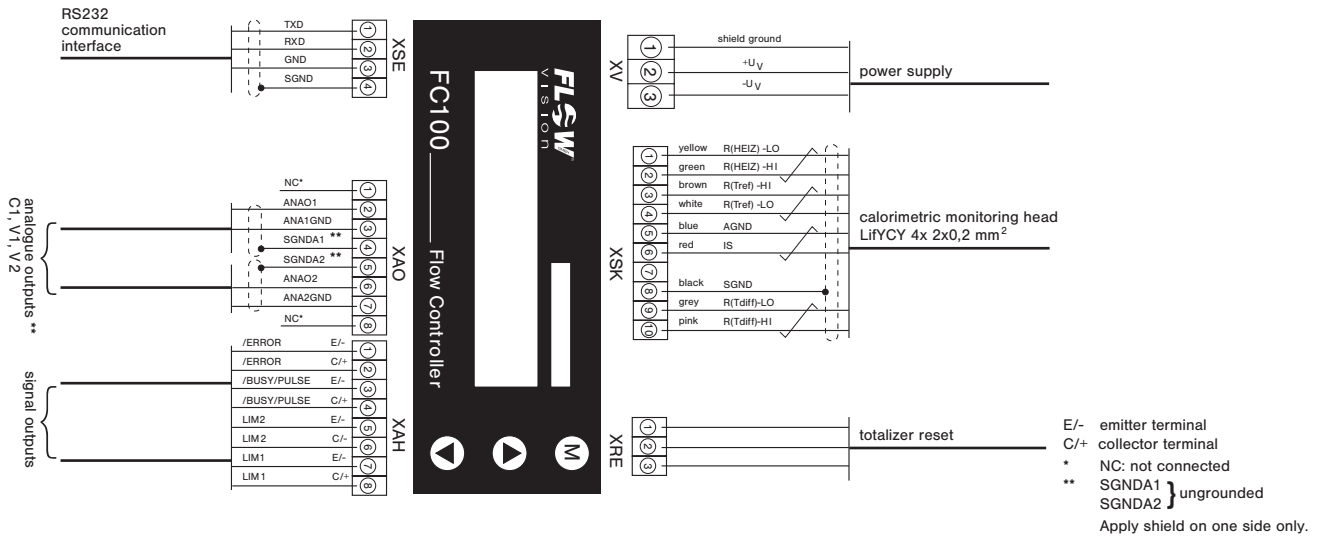

FC100-CA - Recommended connection of pulse output

Electronic signal processing

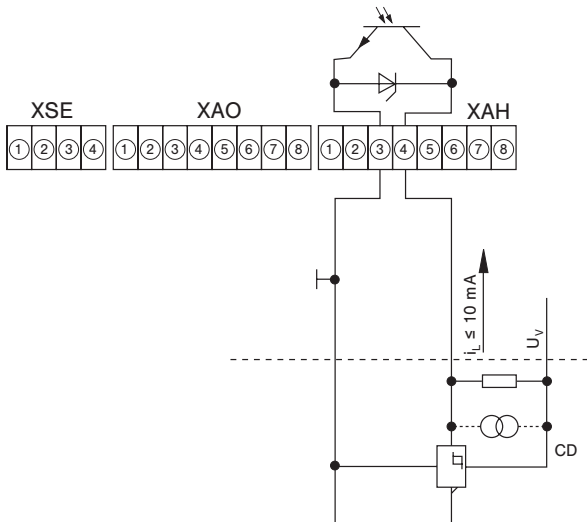

Electromagnetic pulse counter

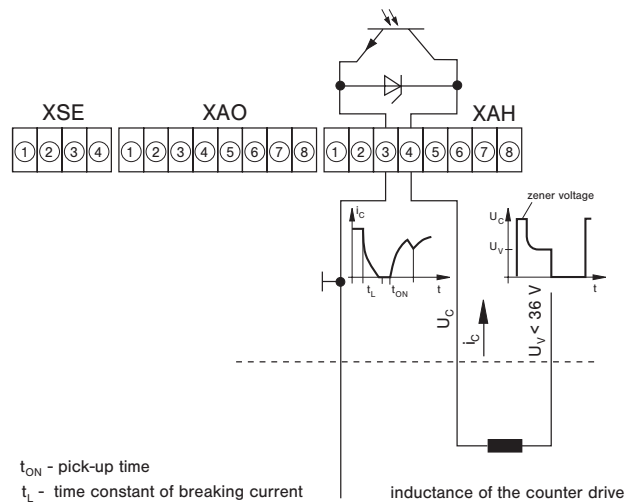

PC-Software

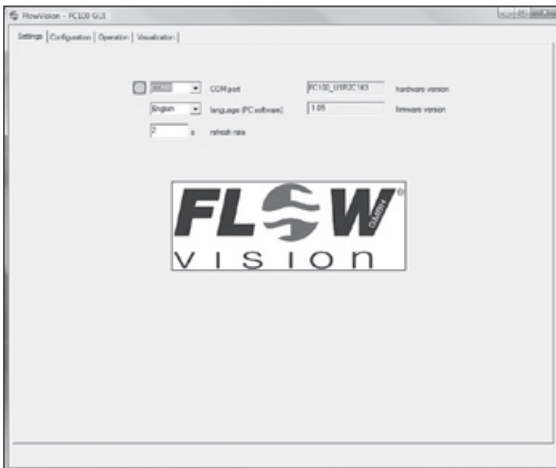

General Settings:

- Selection of the language of the PC software
- Definition how often measuring values are read from the FC100
- Indication of hardware and firmware version

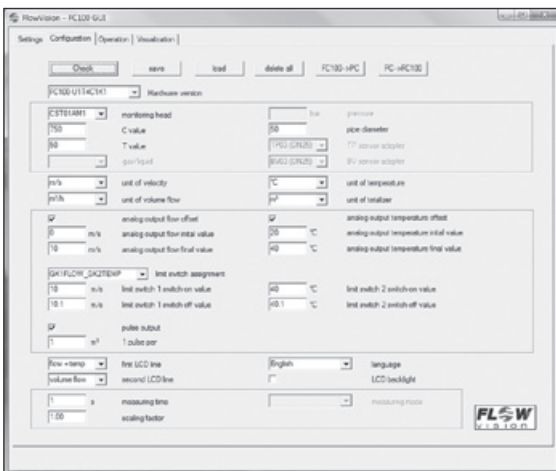

Configuration of the FC100:

- Basic settings (e.g. type of measuring head, pipe size)
- Selection of the units of all measured values
- Configuration of the analogue and signal outputs and the pulse output
- Settings of the display and further configuration possibilities



Operation of the FC100:

- Indication of the actual measured values and saved minimum and maximum values
- Indication of the actual condition of the signal outputs
- Logging of all measured values - export to Microsoft® Excel®

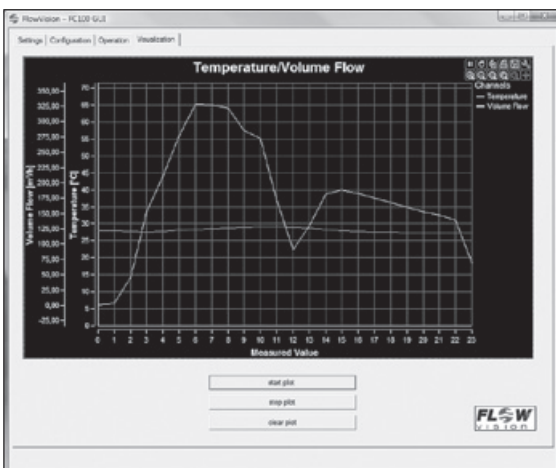

Visualization of the measured values:

- Plot of the measured values (volume flow and temperature)
- Flexible indication of the measured values (e.g. scale, zoom, scroll)

Microsoft and Excel are either registered trademarks or trademarks of Microsoft Corporation in the United States and/or other countries.

A

1

2

3

4

5

6

7

8

9

10

11

12

13

14

15

16

17

18

19

B

Description

A Thread-mounted calorimetric monitoring head for flow Meter FC100, suitable for general industry applications.

Features

- Suitable for installation in welding bushes
- Medium temperature: -40 °C ... +130 °C/-40 °F ... +266 °F
- Material: stainless steel 1.4571/AISI 316 Ti, Hastelloy alloy C4 2.4610 or titanium G7 3.7235

Ordering information

Type No.	CST	Thread-mounted monitoring head with calorimetric sensors
Process connection	01	thread size G1/2A
	03	thread size NPT 1/2"
Medium	A	air
	W	water
Material of areas exposed to medium	M1	stainless steel 1.4571/AISI 316 Ti (standard)
	M2	nickel-based alloy Hastelloy alloy C4 2.4610
	M6	titanium G7 3.7235
Length of shank/thread	L10	36 mm/1.42 in. (standard)
Electrical connection	E10	round connector with tinned contacts (plug and cable to order separately)
Certification	T0	without certificate (standard) *
Specification of medium	xxx	

CST - 01 A M1 L10 E10 T0 - ... ordering example

*) for detailed information please see section 0.

Dimensions

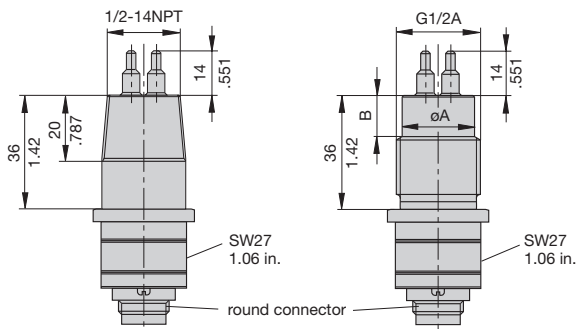

	øA		B	
	mm	inch	mm	inch
G1/2A	18	.709	10	.394

Thread-mounted calorimetric monitoring head



CST-01

Technical data

Type of head	thread-mounted
Thread	G1/2A (standard), NPT 1/2"
Length of shank	36 mm/1.42 in.
Length of sensor	14 mm/.551 in.
Suitable for	air, water
Temperature range *)	-40 °C ... +130 °C/-40 °F ... +266 °F
(of gas/water)	
Temperature drift of monitoring head	± < 0.05 %/°C/measuring range / ± < 0.09 %/°F/measuring range (T = +20 °C ... +80 °C/+68 °F ... +176 °F)
Measuring ranges	
air:	0 ... 20 m/s / 0 ... 65.6 fps
water:	0 ... 3 m/s / 0 ... 9.84 fps
Pressure resistance (1)	100 bar/1450 psi
Degree of protection (2)	IP67
Material	stainless steel 1.4571/AISI 316 Ti Hastelloy C4 2.4610 titanium G7 3.7235
Cable to electronic control unit	LifYCY 4x2x0.2 mm ² /4x2x0.31·10 ⁻³ in. ² (AWG 24)

(1) Admissible operating pressure DIN 2401, measured at max. temperature (= max. medium temperature)

(2) with mating connector

*) max. +85 °C/+185 °F in the connector area

This is a metric design and millimeter dimensions take precedence ($\frac{mm}{inch}$)

Cable types 15/18 with connectors



Do + Ka type 15
Do + Ka type 18

Technical data

Cable type 15

Features: highly flexible, paired, fully shielded, electrical and thermal properties at +20 °C/+68 °F

Conductor resistance:	92 Ω/km
Insulation resistance:	20 MΩ x km
Operating voltage:	250 V
Withstand voltage:	500 V
Max. load:	2 A
Temperature range:	-10 °C ... +80 °C/+14 °F ... +176 °F (processing and operation) -30 °C ... +80 °C/-22 °F ... +176 °F (transport and storage)

Cable type 18

Features: non-halogenous, highly flexible, cold- and heat resistant, paired, fully shielded, electrical and thermal properties at +20 °C/+68 °F

Conductor resistance:	80 Ω/km
Insulation resistance:	1200 MΩ x km
Operating voltage:	300 V
Withstand voltage:	1500 V
Max. load:	3 A
Temperature range:	-50 °C ... +180 °C/-58 °F ... +356 °F

Ordering information

Type between calorimetric monitoring heads CST and FC100, FC100-FH

Do + Ka type 15	PVC insulated cable, type LifYCY 4x2x0.2 mm ² (AWG 24) 8-pole round connector + 10-pole clamping connector
Do + Ka type 18	silicone insulated cable, type 4x2x0.2 mm ² (AWG 24) 8-pole round connector + 10-pole clamping connector

Available cable lengths

...m	2 m/6.56 ft, 3 m, 5 m/16.4 ft, 8 m, 10 m/32.8 ft, 15 m, 20 m/65.6 ft, 25 m, 30 m, 40 m, 50 m, 60 m, 70 m, 80 m, 90 m, 100 m, 110 m, 120 m, 130 m, 140 m, 150 m, 160 m, 170 m, 180 m, 190 m, 200 m/656 ft, (up to max 656 ft)
------	--

Do + Ka type 15 - 2 m ordering example

Description

Cable between Flow Meter FC100-xxx and calorimetric monitoring head type CST.

- Connection to monitoring head by means of 8-pole round connector
- Connection to FC100-xxx by means of 10-pole clamping connector (XSK)

Accessories

8-pole round connector

(without cable, for individual wiring by customer)
0Z112Z003124

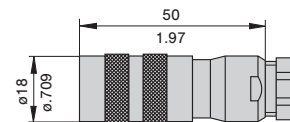

10-pole clamping connector for cable types 15 and 18

(without cable, for individual wiring by customer)
0Z112Z000167

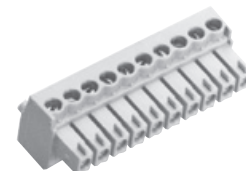

Reducing piece

from G3/4 to G1/2
Material: stainless steel 1.4571/AISI Ti 316
0Z032Z000149

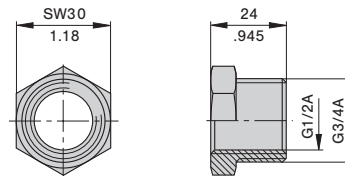

This is a metric design and millimeter dimensions take precedence ($\frac{\text{mm}}{\text{inch}}$)

Standard warranty cover will be invalidated if the correct FlowVision monitoring head/control unit connecting cable is not used.

A

1

2

3

4

5

6

7

8

9

10

11

12

13

14

15

16

17

18

19

B

Description

Extended calorimetric monitoring head with variable immersion depth for Flow Meter FC100, suitable for use in pipelines with process connections DN 50 plus.

Caution: Fix with locking set 01 (see accessories).

Features

- Medium temperature range: -40 °C ... +130 °C/-40 °F ... +266 °F
- Material: stainless steel 1.4571/AISI 316 Ti

Ordering information

Type	CSF	Extended monitoring head with calorimetric sensors
		Monitoring head design
	01	Monitoring head with variable immersion depth
		Medium
	A	air
	W	water
		Material of areas exposed to medium
	M1	stainless steel 1.4571/AISI 316 Ti
		Process connection
	00	without flange; see accessories for connections
		Length of shank/thread
	L43	188 mm/7.40 in. (standard) other lengths upon request
		Electrical connection
	E10	round connector with tinned contacts (plug and cable to order separately)
		Certification
	T0	without certificate (standard *)
		Specification of medium
	xxx	
CSF - 01 A M1 00 L43 E10 T0 - ...		ordering example

*) for detailed information please see section 0

Dimensions

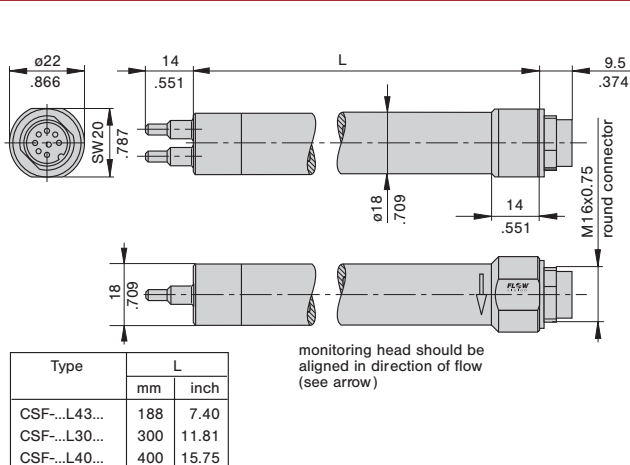

This is a metric design and millimeter dimensions take precedence ($\frac{\text{mm}}{\text{inch}}$)

Monitoring head CSF



CSF-01
variable immersion depth

Technical data

Type of head	push-in
Shank diameter	18 mm/.709 in.
Length of shank	188 mm/7.40 in.
Length of sensor	14 mm/.551 in.
Suitable for	air, water
Temperature range* (of gas/water)	-40 °C ... +130 °C/-40 °F ... +266 °F
Temperature drift of sensor	± < 0.05 %/°C/measuring range ± < 0.09 %/°F/measuring range (T = +20 °C ... +80 °C/+68 °F ... +176 °F)
Measuring ranges	air: 0 ... 20 m/s / 0 ... 65.6 fps (atm. press.) water: 0 ... 3 m/s / 0 ... 9.84 fps
Pressure resistance (1) (sensor)	100 bar/1450 psi
Pressure resistance (1) (installation)	depending on connection (see accessories)
Degree of protection (2)	IP67
Material	stainless steel 1.4571/AISI 316 Ti
Cable to electronic unit	LifYCY 4x2x0.2 mm ² /4x2x0.31·10 ⁻³ in. ² (AWG 24)

(1) Admissible operating pressure DIN 2401, measured at max. temperature (= max. medium temperature)

(2) with mating connector

*) max. +85 °C/+185 °F in the connector area

Cable types 15/18 with connectors



Do + Ka type 15
Do + Ka type 18

Technical data

Cable type 15

Features: highly flexible, paired, fully shielded, electrical and thermal properties at +20 °C/+68 °F

Conductor resistance:	92 Ω/km
Insulation resistance:	20 MΩ x km
Operating voltage:	250 V
Withstand voltage:	500 V
Max. load:	2 A
Temperature range:	-10 °C ... +80 °C/+14 ° F ... +176 °F (processing and operation) -30 °C ... +80 °C/-22 ° F ... +176 °F (transport and storage)

Cable type 18

Features: non-halogenous, highly flexible, cold- and heat resistant, paired, fully shielded, electrical and thermal properties at +20 °C/+68 °F

Conductor resistance:	80 Ω/km
Insulation resistance:	1200 MΩ x km
Operating voltage:	300 V
Withstand voltage:	1500 V
Max. load:	3 A
Temperature range:	-50 °C ... +180 °C/-58 °F ... +356 °F

Description

Cable between Flow Meter FC100-xxx and calorimetric monitoring head type CSF.

- Connection to monitoring head by means of 8-pole round connector
- Connection to FC100-xxx by means of 10-pole clamping connector (XSK)

Ordering information

Type between calorimetric monitoring heads CSF and FC100, FC100-FH

Do + Ka type 15	PVC insulated cable, type LifYCY 4x2x0.2 mm ² (AWG 24) 8-pole round connector + 10-pole clamping connector
Do + Ka type 18	silicone insulated cable, type 4x2x0.2 mm ² (AWG 24) 8-pole round connector + 10-pole clamping connector

Available cable lengths

...m	2 m, 3 m, 5 m, 8 m, 10 m, 15 m, 20 m, 25 m, 30 m, 40 m, 50 m, 60 m, 70 m, 80 m, 90 m, 100 m, 110 m, 120 m, 130 m, 140 m, 150 m, 160 m, 170 m, 180 m, 190 m, 200 m/656 ft (up to max 656 ft)
-------------	---

Do + Ka type 15 - 2 m ordering example

A

1

2

3

4

5

6

7

8

9

10

11

12

13

14

15

16

17

18

19

B

Accessories

8-pole round connector
(without cable, for individual wiring by customer)
OZ112Z003124

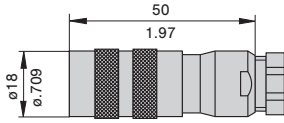

10-pole clamping connector for cable types 15 and 18
(without cable, for individual wiring by customer)
OZ112Z000167

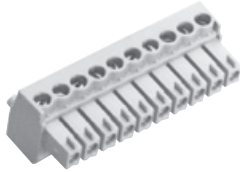

PG16 nickel-plated brass
(standard)
OZ122Z000128

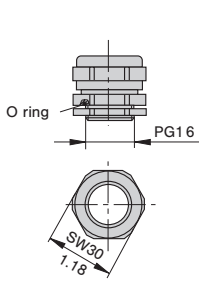

pressure resistant up to 2 bar/29.0 psi

NPT3/4" moulded, black
OZ122Z000131

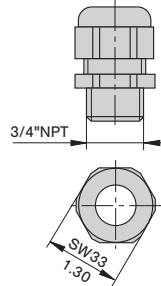

pressure resistant up to 2 bar/29.0 psi

This is a metric design and millimeter dimensions take precedence ($\frac{\text{mm}}{\text{inch}}$)

Threaded installation bush
OZ122Z000196

Teflon sealing ring
OZ122Z000197

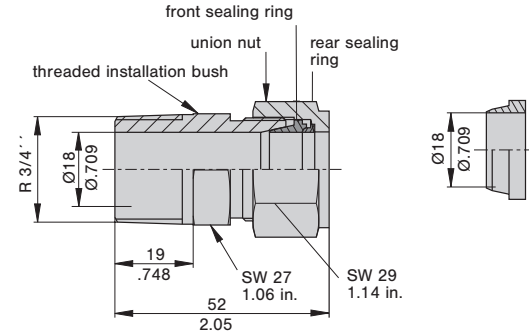

Suitable up to 25 bar/363 psi if used with stainless steel CSF-01 monitoring head.
(Observe instructions for installation)

Caution: Stainless steel ring is designed to cut into monitoring head.
Pressure resistant to 25 bar/363 psi.
Teflon ring can only be used from 0 to 2 bar/29.0 psi.

Please observe user manual!

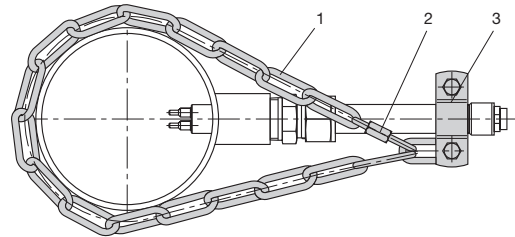

- 1 chain 4 x 32 DIN 5685 (approx. 1 m/3.28 ft)
- 2 catch for chain NG 5
- 3 clip with screw and nuts DN15 to DIN 11850

Caution: Standard warranty cover will be invalidated if the correct FlowVision monitoring head/control unit connecting cable is not used.

A

1

2

3

4

5

6

7

8

9

10

11

12

13

14

15

16

17

18

19

B

Flange-mounted calorimetric monitoring head



CSF-03
Tri-Clamp

Technical data

Type of head	flange-mounted monitoring head
Process connection	DIN 32676 Tri-Clamp® DN 1
Shank dia.	18 mm/0.709 in.
Length of shank	15 mm/0.591 in.
Length of sensor	14 mm/0.551 in.
Suitable for	water
Temperature range *)	-40 °C...+130 °C/-40 °F ... +266 °F
(of water)	
Temperature drift of monitoring head	± < 0.05 %/°C/measuring range ± < 0.09 %/°F/measuring range (T = +20 ... +80 °C/+68 ... +176 °F)
Measuring range	0 ... 3 m/s / 0 ... 9.84 fps
Pressure resistance ⁽¹⁾	40 bar/580 psi
Degree of protection ⁽²⁾	IP67
Material	stainless steel 1.4571/AISI 316 Ti
Cable to electronic control unit	LifYCY 4x2x0.2 mm ² /4x2x0.31·10 ⁻³ in. ² (AWG 24)

⁽¹⁾ Admissible operating pressure DIN 2401, measured at max. temperature (= max. medium temperature)
⁽²⁾ with mating connector
^{*)} max. +85 °C/+185 °F in the connector area

Description

Flange-mounted calorimetric monitoring head for Flow Meter FC100. Recommended for food-processing (Tri-Clamp®).

Features

- Medium temperature range: -40 °C ... +130 °C/-40 °F ... +266 °F
- Material: stainless steel 1.4571/AISI 316 Ti

Ordering information

Type	flange-mounted monitoring head with calorimetric sensors
CSF	flange-mounted monitoring head with calorimetric sensors
	Monitoring head design
	03 monitoring head with flange DIN 32676
	Medium
	W water
	Material of areas exposed to medium
	M1 stainless steel 1.4571/AISI 316 Ti
	Process connection
	91 flange DIN 32676-Tri-Clamp® DN1
	Length of shank/thread
	L90 15 mm/0.591 in. (standard)
	Electrical connection
	E10 round connector with tinned contacts (plug and cable to separate order)
	Certification
	T0 without certificate (standard *)
	Specification of medium
	xxx
CSF - 03 W M1 91 L90 E10 T0 - ...	ordering example

*) for detailed information please see section 0.

Dimensions

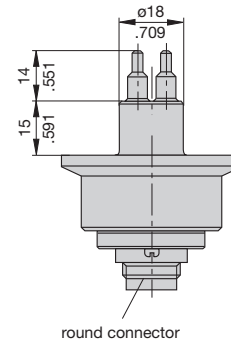

This is a metric design and millimeter dimensions take precedence (mm/inch)

- A
- 1
- 2
- 3
- 4
- 5
- 6
- 7
- 8
- 9
- 10
- 11
- 12
- 13
- 14
- 15
- 16
- 17
- 18
- 19
- B

Cable types 15/18 with connectors



Do + Ka type 15
Do + Ka type 18

Technical data

Cable type 15

Features: highly flexible, paired, fully shielded, electrical and thermal properties at +20 °C/+68 °F

Conductor resistance:	92 Ω/km
Insulation resistance:	20 MΩ x km
Operating voltage:	250 V
Withstand voltage:	500 V
Max. load:	2 A
Temperature range:	-10 °C ... +80 °C/+14 ° F ... +176 °F (processing and operation) -30 °C ... +80 °C/-22 ° F ... +176 °F (transport and storage)

Cable type 18

Features: non-halogenous, highly flexible, cold- and heat resistant, paired, fully shielded, electrical and thermal properties at +20 °C/+68 °F

Conductor resistance:	80 Ω/km
Insulation resistance:	1200 MΩ x km
Operating voltage:	300 V
Withstand voltage:	1500 V
Max. load:	3 A
Temperature range:	-50 °C ... +180 °C/-58 °F ... +356 °F

Ordering information

Type between calorimetric monitoring heads **CSF** and **FC100, FC100-FH**

Do + Ka type 15	PVC insulated cable, type LifYCY 4x2x0.2 mm ² (AWG 24) 8-pole round connector + 10-pole clamping connector
Do + Ka type 18	silicone insulated cable, type 4x2x0.2 mm ² (AWG 24) 8-pole round connector + 10-pole clamping connector

Available cable lengths

...m	2 m/6.56 ft, 3 m, 5 m/16.4 ft, 8 m, 10 m/32.8 ft, 15 m, 20 m/65.6 ft, 25 m, 30 m, 40 m, 50 m, 60 m, 70 m, 80 m, 90 m, 100 m, 110 m, 120 m, 130 m, 140 m, 150 m, 160 m, 170 m, 180 m, 190 m, 200 m/656 ft, (up to max 656 ft)
-------------	--

Do + Ka type 15 - 2 m ordering example

Description

Cable between Flow Meter FC100-xxx and calorimetric monitoring head type CSF-03 (Tri-Clamp®).

- Connection to monitoring head by means of 8-pole round connector
- Connection to FC100-xxx by means of 10-pole clamping connector (XSK)

Accessories

8-pole round connector

(without cable, for individual wiring by customer)
OZ112Z003124

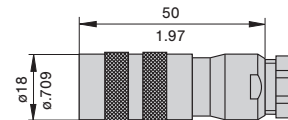

10-pole clamping connector for cable types 15 and 18

(without cable, for individual wiring by customer)
OZ112Z000167

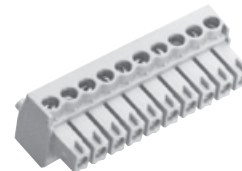

This is a metric design and millimeter dimensions take precedence ($\frac{\text{mm}}{\text{inch}}$)

Standard warranty cover will be invalidated if the correct FlowVision monitoring head/control unit connecting cable is not used.