

Description

Microcontroller operated flow meter for water (other liquids upon request). Particularly suited to volume flow measurements with simultaneous measurement of water temperature. Suitable for use with calorimetric monitoring heads.

1

Features

- Menu driven (keypads)
- LC display (2 x 16 digits) of:
 - current flow velocity, volume flow, temperature
 - bargraph status indication of limit contacts, actual flow rate/ quantity or medium temperature;
 - directions for parameter assignment, configuration, diagnosis and error correction;
 - base value indication
- Two scalable analogue outputs
- Minimum/maximum memory of flow velocity and temperature
- Two freely selectable limit contacts
- pulse output calibrated to volume flow

Ordering information

Type	
FC01-LQ	Flow Meter with software for water, rail-mounted
FC01-FH-LQ	Flow Meter with software for water, surface mounted
FC01-ST-LQ	Flow Meter with software for water, front panel mounted
Input voltage	
U1	DC 19 ... 32 V
Signal outputs	
R2	2 relay outputs (2 limit values)
T4	4 transistor outputs (2 limit values + 2 status, or 2 limit values + 1 status + 1 pulse output)
Analogue outputs	
V1	0/1- 5 Volt
V2	0/2-10 Volt
C1	0/4-20 mA (self-powered, physically isolated)
FC01-LQ - U1 R2 V1	ordering example



Dimensions

FC01-LQ (rail-mounted housing)

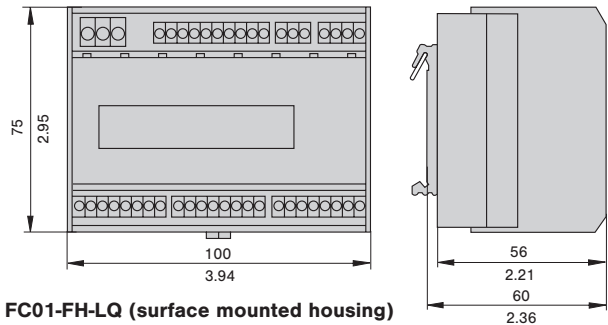

FC01-FH-LQ (surface mounted housing)

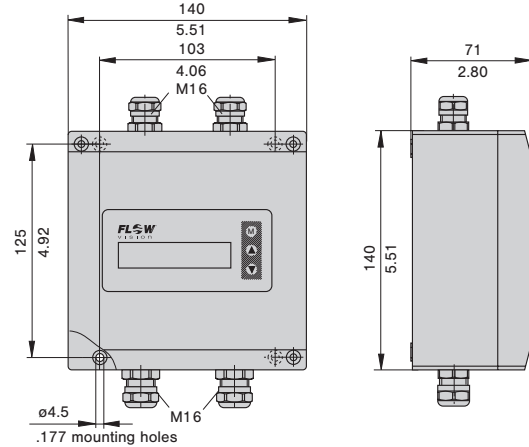

FC01-ST-LQ (front panel mounted housing)

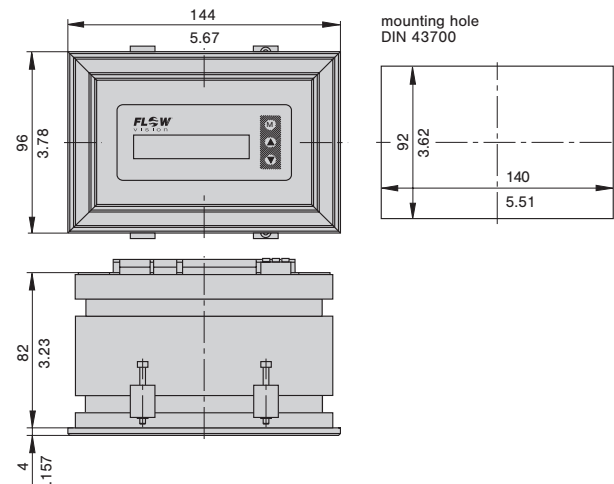

This is a metric design and millimeter dimensions take precedence ($\frac{mm}{inch}$)

TECHNICAL DATA			
Flow Meter FC01-LQ		with CSP monitoring head and-sensor adapter TP/ball valve BV	with CSF monitoring head
General data			
Suitable for	water (other liquids upon request)		
Measuring functions	flow velocity, volume flow rate, temperature, totalised flow rate		
Display	2 x 16 digit LC display		
Parameter assignment, calibration by	keypads		
Temperature range (electronic control unit) in circulating air	+10 ... +50 °C/+50 ... +122 °F *)		
Electrical data			
Input voltage	DC 24 V (19 ... 32 V)		
Power consumption	DC 200 mA **)		
Analogue outputs	flow and temperature	0/4-20 mA or 0/2-10 V or 0/1-5 V	
Signal outputs	2 relay outputs (2 limit values)	2 SPDT contacts AC/DC 50 V / 1 A / 50 W	
	4 transistor outputs (2 limit values + 2 status oder 2 limit values +1 status +1 pulse output)	open collector outputs DC 36 V / 150 mA / 1,5 W	
Flow measurement			
Measuring range 0.05 ... 3 m/s / 0.164 ... 9.84 fps (display range 0 ... 4 m/s / 0 ... 13.1 fps)	in TP-01	0,02 - 2,2 (2,9) m³/h	see table flow measurement range (next page)
	in TP-02	0,04 - 3,4 (4,5) m³/h	
	in TP-03	0,05 - 5,3 (7,1) m³/h	
	in TP-04	0,10 - 8,7 (11,6) m³/h	
	in TP-05	0,14 - 13,6 (18,1) m³/h	
in TP-06	0,20 - 21,2 (28,3) m³/h		
Accuracy ⁽⁵⁾	see failure diagram		
Repeatability (5 % MRFV - 100 % MRFV) ⁽²⁾	±1% of measured value ±0.5 % of measuring range final value		
Temperature drift of electronic control unit ⁽¹⁾	0.05 %/°C/measuring range final value 0.09 %/°F/measuring range final value		
Pressure error	±0.5 %/bar / ±0.5 %/14.5 psi of measured value		
Temperature measurement			
Measuring range	-40 ... +130 °C/-40 ... +266 °F		
Accuracy	±1 % of measuring range		
Mechanical data (electronic control unit)			
Degree of protection	rail-mounted	IP20	
	surface mounted	IP65	
	front panel mounted	IP65	
Materials	rail-mounted	acrylic vinyl/ styrene/ polycarbonate; heat sink aluminium	
	surface mounted	aluminium acryl	
	front panel mounted	aluminium black coated; display polyester foil	
Housing dimension (LxWxH)	see dimension diagram (previous page)		
Weight	rail-mounted	485 g/1.07 lb	
	surface mounted	1250 g/2.76 lb	
	front panel mounted	900 g/1.98 lb	
Cables	voltage supply	3x0,75 mm² (AWG 18)	
	to monitoring head	LifYCY 4x2x0,2 mm² (AWG 24)	
	analogue outputs	2 x LifYCY 2x0,25 mm² (AWG 24)	
	limit value output	2 x LifYCY 3x0,38 mm² (AWG 22)	
Max. cable length to monitoring head	200 m/656 ft		
<p>*) With output C1 the max. admissible ambient temperature for the rail-mounted version is limited to +40 °C/+104 °F. **) With output C1, power consumption may be up to 300 mA ± 10 %. (1) Warm-up time to full accuracy: 15 minutes. (2) Of the set value, at constant temperature and flow conditions and stable thermal conductivity. (5) The accuracy values were determined under ideal conditions: - symmetrical complete flow profile - correct mounting in the pipe - inlets and outlets according to EN ISO 5167-1 MRFV = measuring range final value</p>			

1

Block diagram

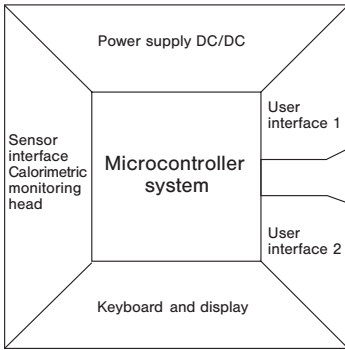

- Input voltage: DC 19 ... 32 V
- Keyboard/display: keypads
LC display
2 x 16 digits
- User interface 1: relay outputs: 2 limit values
transistor outputs: 2 limit values +
1 error indication +
1 busy or quantity dependent
pulse output (software selected)
- User interface 2: analogue outputs
current or voltage
- Controller system: signal processing
I/O - controlling
monitoring
parameter memory
- Sensor interfaces: calorimetric monitoring head

Connection diagram

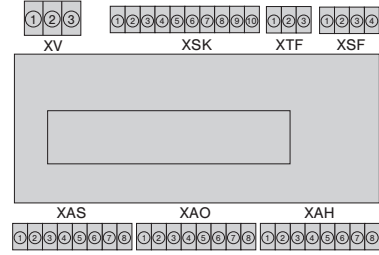

- Wire size: 0.14 mm² to 1.5 mm² single or finely stranded conductor
- Stripping length: 6.5 mm
- Clamping screw: M2 (nickel-plated brass)
- Contact material: pre-tinned tin bronze

- XV: current supply
- XSK: calorimetric monitoring head
- XTF: keyboard release
- XSF: not released for user
- XAS: not released for user
- XAO: analogue outputs
- XAH: signal outputs

Flow measurement range (CSF-11.. monitoring head)

The flow measurement range is determined by the inside pipe diameter (see table). It can be calculated with the following equation:

$$Q = V_N \times A_R$$

Q (m³/h) - flow quantity
V_N (m/h) - average standard velocity
A_R (m²) - inside pipe diameter

Setting range for inside pipe diameter:
50.0 mm ... 999.9 mm/1.97 in. ... 39.4 in.
velocity measuring range:
0 ... 3 m/s (0 ... 4 m/s)/0 ... 9.84 fps (0 ... 13.1 fps)

inside pipe diameter	measuring range	display range
D in mm	in m ³ /h	in m ³ /h
50	21	28
80	55	70
100	85	110
150	190	250
200	340	450
250	530	700
350	1040	1380
500	2120	2830

Failure diagram for water

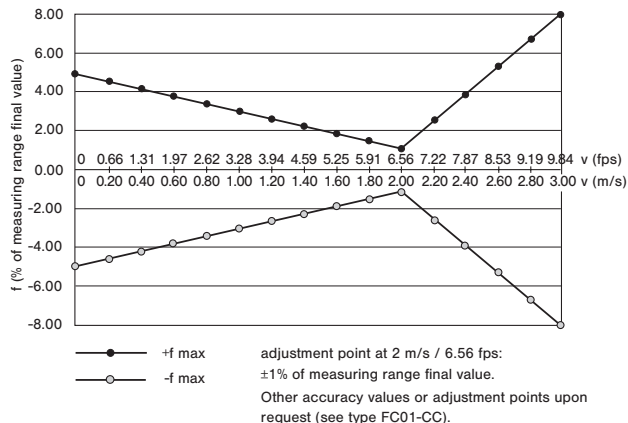

Connection diagrams

FC01-LQ with relay outputs

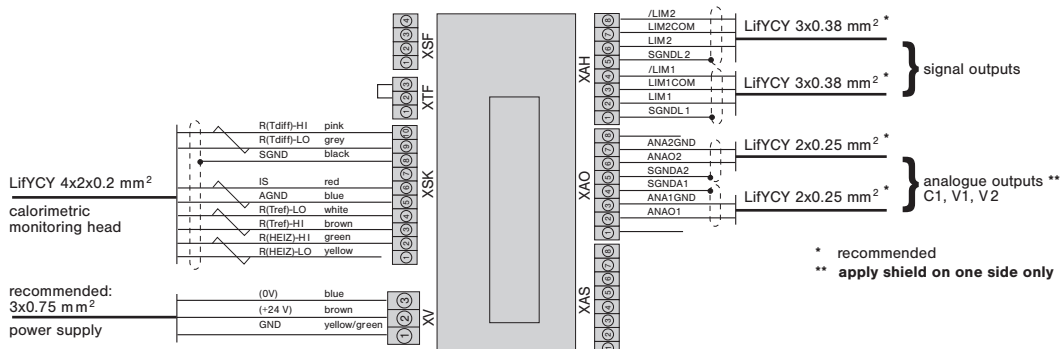

FC01-LQ with transistor outputs

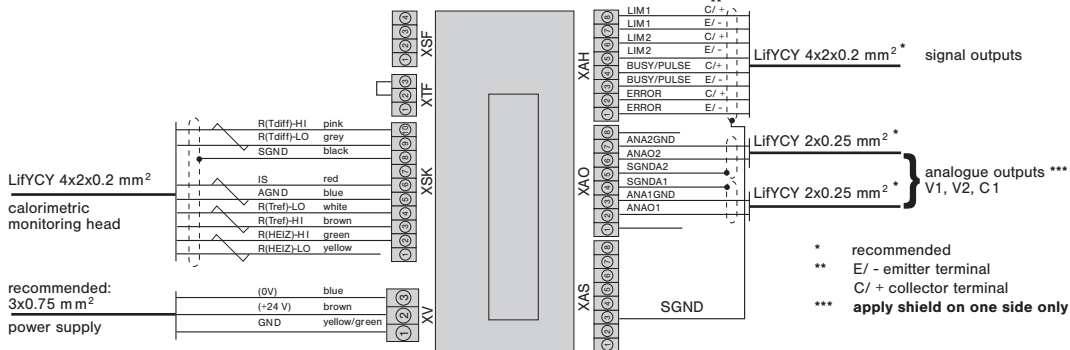

FC01-LQ - Recommended connection of pulse output

Electronic signal processing

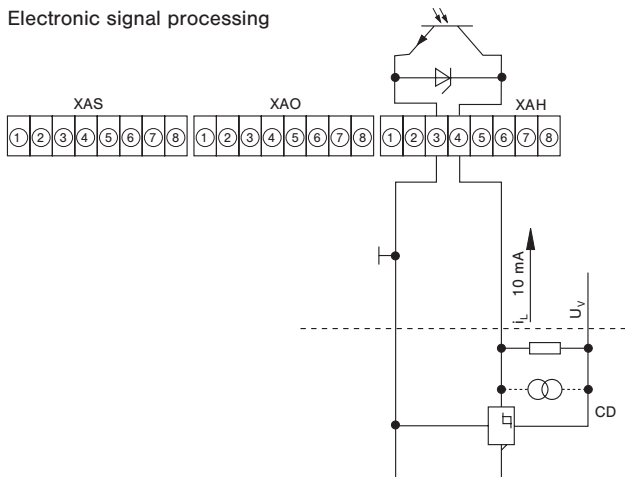

Electromagnetic pulse counter

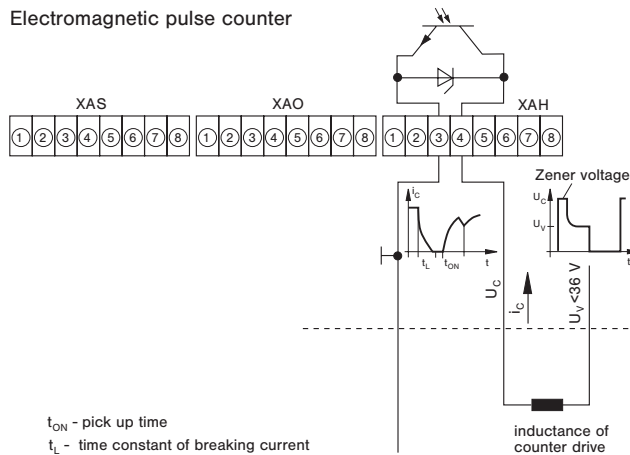

All dimensions without tolerances are for reference only. In the interest of improved design, performance and cost effectiveness the right to make changes in these specifications without notice is reserved. Product markings may not be exactly as the ordering codes. Errors and omissions excepted.

1

Description

Sensor adapters TP and ball valves BV facilitate correct positioning and exchange of CSP monitoring heads, FC03, FC04 or FS10 in pipes with process connection DN 15 ... DN 50.

Ball valve BV enables pressure-free installation and removal of CSP monitoring heads and Flow Meters FC03, FC04 and Flow Monitor FS10 simply by closing the input and output pipe. The measuring points are suited to temporary measurements; after completion of the measuring cycle they can be closed by means of blanking plugs.

Sensor adapter TP... / Ball valve BV...

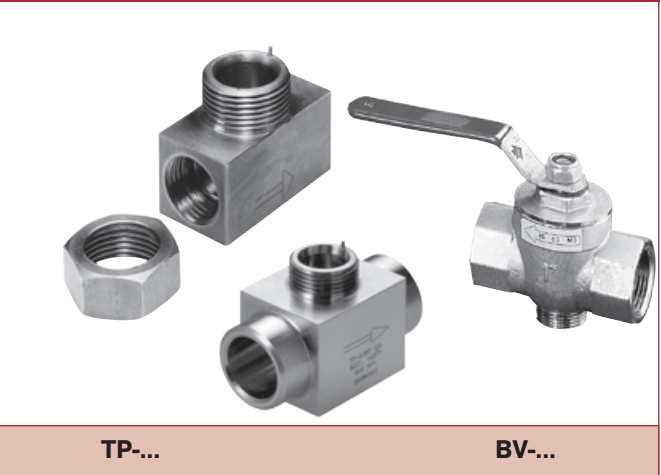

TP-...

BV-...

Features

- Correct positioning of sensor
- Ease of sensor replacement
- Measuring point can be closed if not used
- Sensor adapter available as screw-in or welding type
- Ball valve also serves as a shutoff valve (both input and output)

Ordering information

Type	
BV	ball valve with internal thread
Process connection/Nominal size	
03	DN 25 G1 internal thread length: 88 mm/3.46 in.
04	DN 32 G1 1/4 internal thread length: 100 mm/3.94 in.
05	DN 40 G1 1/2 internal thread length: 110 mm/4.33 in.
06	DN 50 G2 internal thread length: 131 mm/5.16 in.
Material of the area exposed to medium	
M3	nickel plated brass, Delrin seal
BV - 03	M3 ordering example

Ordering information

Type	
TP	Sensor adapter with internal thread
Process connection/Nominal size	
01	DN 15 G1/2 internal thread length: 50 mm/1.97 in.
02	DN 20 G3/4 internal thread length: 64 mm/2.52 in.
03	DN 25 G1 internal thread length: 78 mm/3.07 in.
04	DN 32 G1 1/4 internal thread length: 94 mm/3.70 in.
05	DN 40 G1 1/2 internal thread length: 110 mm/4.33 in.
06	DN 50 G2 internal thread length: 138 mm/5.43 in.
Material of the area exposed to medium	
M1	stainless steel 1.4571/AISI 316Ti PN 315 bar/4570 psi
M3	brass (not TP-03..) PN 25 bar/363 psi
M5	red brass (only TP-03..) PN 16 bar/232 psi
TP - 01	M3 ordering example

Accessories

Description	Ref. No.
Blanking plug, brass, with O ring	OZ121Z000186
Union nut, brass	Y 306 901 01
Blanking plug, stainless steel 1.4571/AISI 316 Ti, with viton O ring	OZ121Z000187
Union nut, stainless steel	Y 306 901 03

Ordering information

Type	
TP	Sensor adapter with welding nipples
Process connection/Nominal size	
01	DN 15 dia.d: 16 mm/.630 in. length: 80 mm/3.15 in.
02	DN 20 dia.d: 20 mm/.787 in. length: 70 mm/2.76 in.
03	DN 25 dia.d: 25 mm/.984 in. length: 80 mm/3.15 in.
04	DN 32 dia.d: 32 mm/1.26 in. length: 100 mm/3.94 in.
05	DN 40 dia.d: 40 mm/1.57 in. length: 110 mm/4.33 in.
06	DN 50 dia.d: 50 mm/1.97 in. length: 140 mm/5.51 in.
Material of the area exposed to medium	
M1	stainless steel 1.4571/AISI 316Ti
Process connection	
SA	welded connection
TP - 01	M1 - SA ordering example

Dimensions

TP-... Sensor adapter with internal thread

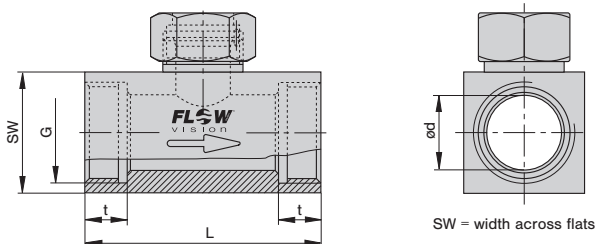

Material stainless steel (-M1): PN 315 bar / 4570 psi
 Material brass (-M3): PN 25 bar / 363 psi
 Material red brass (-M5): PN 16 bar / 232 psi

Type	DN		dia. d		G	t		L		SW	
	mm	in.	mm	in.	in.	mm	in.	mm	in.	mm	in.
TP-01 ...	15	.591	16	.630	1/2"	11	.433	50	1.97	27	1.06
TP-02 ...	20	.787	20	.787	3/4"	12	.472	64	2.52	32	1.26
TP-03 ...	25	.984	25	.984	1"	14	.551	78	3.07	40	1.57
TP-04 ...	32	1.26	32	1.26	1 1/4"	15	.591	94	3.70	50	1.97
TP-05 ...	40	1.57	40	1.57	1 1/2"	15	.591	110	4.33	55	2.16
TP-06 ...	50	1.97	50	1.97	2"	19	.748	138	5.43	70	2.76

TP-..M1-SA Sensor adapter with welding nipples

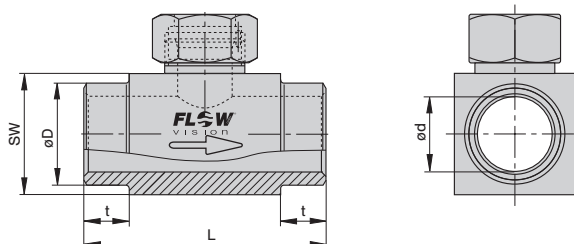

PN 315 bar / 4570 psi

Type	DN		dia. d		dia. D		t		L		SW	
	mm	in.	mm	in.	mm	in.	mm	in.	mm	in.	mm	in.
TP-01M1-S A	15	.591	16	.630	21.3	.839	15	.591	80	3.15	27	1.06
TP-02M1-S A	20	.787	20	.787	26.9	1.06	15	.591	70	2.76	32	1.26
TP-03M1-S A	25	.984	25	.984	33.7	1.33	15	.591	80	3.15	40	1.57
TP-04M1-S A	32	1.26	32	1.26	42.4	1.67	15	.591	100	3.94	50	1.97
TP-05M1-S A	40	1.57	40	1.57	48.3	1.90	15	.591	110	4.33	55	2.16
TP-06M1-S A	50	1.97	50	1.97	60.3	2.37	15	.591	140	5.51	70	2.76

BV-...M3 Ball valve with internal thread

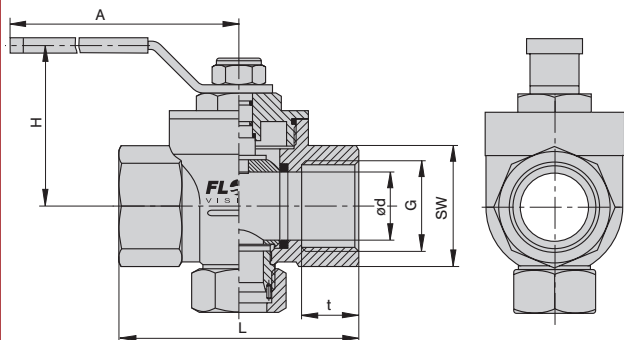

PN 25 bar / 363 psi

Type	DN		dia. d		G	t		L		SW		H		A	
	mm	in.	mm	in.	in.	mm	in.	mm	in.	mm	in.	mm	in.	mm	in.
BV-03M 3	25	.984	25	.984	1"	21	.827	88	3.46	41	1.61	59	2.32	115	4.53
BV-04M 3	32	1.26	32	1.26	1 1/4"	24	.945	100	3.94	50	1.97	65	2.56	115	4.53
BV-05M 3	40	1.57	40	1.57	1 1/2"	24	.945	110	4.33	54	2.13	77	3.03	150	5.91
BV-06M 3	50	1.97	50	1.97	2"	28	1.10	131	5.16	70	2.76	85	3.35	150	5.91

This is a metric design and millimeter dimensions take precedence ($\frac{mm}{inch}$)

1

Description

Calorimetric plug-in type monitoring head for sensor adapter TP/BV and flow meter FC01-LQ, suitable for use with liquids and pipe sizes up to DN 50. Calibrated in water.

Features

- Ease of installation
- Small physical size
- Medium temperature range -40 ... +130 °C/-40 ... +266 °F
- Material: stainless steel 1.4571/AISI 316 Ti
- Sealing: Viton o-ring

Ordering information

Type No.	
CSP	plug-in type monitoring head with calorimetric sensors
11	plug-in type
Medium	
W	water (standard)
Material of areas exposed to medium	
M1	stainless steel 1.4571/AISI 316 Ti (standard)
Length of shank/thread	
L05	18.2 mm/.717 in. (standard)
Electrical connection	
E10	round connector with tinned contacts (plug and cable to order separately)
Certification	
T0	without certificate (standard) *)
Specification of medium	
xxx	
CSP - 11 W M1 L05 E10 T0 - ...	ordering example

*) for detailed information please see section 0.

Dimensions

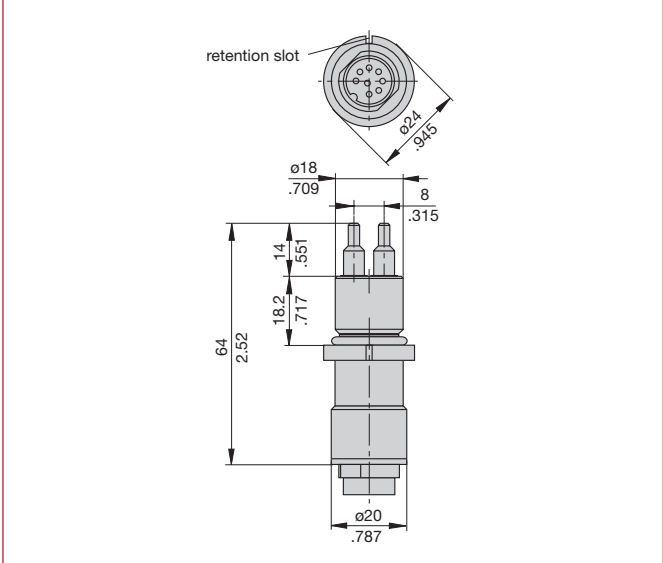

This is a metric design and millimeter dimensions take precedence (mm/inch)

Monitoring head CSP



CSP-11

Technical data

Type of head	plug-in type
Shank diameter	18 mm/.709 in.
Length of shank	18.2 mm/.717 in.
Length of sensor	14 mm/.551 in.
Suitable for	water (other liquids upon request)
Temperature range *) (of medium)	-40 ... +130 °C/-40 ... +266 °F
Temperature drift of monitoring head	± < 0.05 %/°C/measuring range ± < 0.09 %/°F/measuring range (T = +20 ... +80 °C/+68 ... +176 °F)
Measuring ranges	in TP-01 0.02 - 2.2 (2.9) m³/h in TP-02 0.04 - 3.4 (4.5) m³/h in TP-03 0.05 - 5.3 (7.1) m³/h in TP-04 0.1 - 8.7 (11.6) m³/h in TP-05 0.14 - 13.6 (18.1) m³/h in TP-06 0.2 - 21.2 (28.3) m³/h
Pressure resistance ⁽¹⁾	100 bar/1450 psi
Degree of protection ⁽²⁾	IP67
Material	
housing:	stainless steel 1.4571/AISI 316 Ti laser welded
o-ring:	Viton
Cable to electronic control unit	LifYCY 4x2x0.2 mm² (AWG 24)

⁽¹⁾ Admissible operating pressure DIN 2401, measured at max. temperature (= max. medium temperature)
⁽²⁾ with mating connector
^{*)} max. +85 °C/+185 °F in the connector area

Cable types 15/18 with connectors



Do + Ka type 15
Do + Ka type 18

Do + Ka type 15-ST
Do + Ka type 18-ST

Technical data

Cable type 15 and 15-ST

Features: highly flexible, paired, fully shielded, electrical and thermal properties at +20 °C/+68 °F

Conductor resistance:	92 Ω/km
Insulation resistance:	20 MΩ x km
Operating voltage:	250 V
Withstand voltage:	500 V
Max. load:	2 A
Temperature range:	-10 °C ... +80 °C/+14 °F ... +176 °F (processing and operation) -30 °C ... +80 °C/-22 ° F ... +176 °F (transport and storage)

Cable type 18 and 18-ST

Features: non-halogenous, highly flexible, cold- and heat resistant, paired, fully shielded, electrical and thermal properties at +20 °C/+68 °F

Conductor resistance:	80 Ω/km
Insulation resistance:	1200 MΩ x km
Operating voltage:	300 V
Withstand voltage:	1500 V
Max. load:	3 A
Temperature range:	-50 °C ... +180 °C/-58 °F ... +356 °F

Ordering information

Type between calorimetric monitoring heads **CSP** and **FC01-LQ, FC01-FH-LQ**

Do + Ka type 15 **PVC** insulated cable, type LifYCY 4x2x0,2 mm² (AWG 24)
8-pole round connector + 10-pole clamping connector

Do + Ka type 18 **silicone** insulated cable, type 4x2x0,2mm² (AWG 24)
8-pole round connector + 10-pole clamping connector

Available cable lengths

...m 2 m, 3 m, 5 m, 8 m, 10 m, 15 m, 20 m, 25 m, 30 m, 40 m, 50 m, 60 m, 70 m, 80 m, 90 m, 100 m, 110 m, 120 m, 130 m, 140 m, 150 m, 160 m, 170 m, 180 m, 190 m, 200 m (up to max 656 ft)

Do + Ka type 15 - 2 m/6.56 ft ordering example

Type between calorimetric monitoring heads **CSP** and **FC01-ST-LQ**

Do + Ka type 15-ST **PVC** insulated cable, type LifYCY 4x2x0,2 mm² (AWG 24)
8-pole round connector + 10-pole clamping connector

Do + Ka type 18-ST **silicone** insulated cable, type 4x2x0,2mm² (AWG 24)
8-pole round connector + 10-pole clamping connector

Available cable lengths

...m 2 m, 3 m, 5 m, 8 m, 10 m, 15 m, 20 m, 25 m, 30 m, 40 m, 50 m, 60 m, 70 m, 80 m, 90 m, 100 m, 110 m, 120 m, 130 m, 140 m, 150 m, 160 m, 170 m, 180 m, 190 m, 200 m (up to max 656 ft)

Do + Ka type 15-ST - 2 m/6.56 ft ordering example

Description

Cable between Flow Meter FC01-xxx and calorimetric monitoring head type CSP.

- Connection to monitoring head by means of 8-pole round connector
- Connection to FC01-xxx by means of 10-pole clamping connector (XSK)

1

Accessories

8-pole round connector

(without cable, for individual wiring by customer)
OZ112Z003124

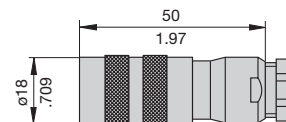

10-pole clamping connector for cable types 15 and 18

(without cable, for individual wiring by customer)
OZ112Z000167

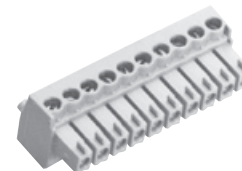

10-pole clamping connector for cable types 15-ST and 18-ST

(without cable, for individual wiring by customer)
OZ112Z000205

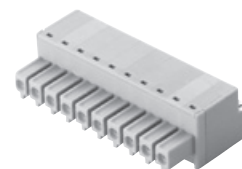

This is a metric design and millimeter dimensions take precedence ($\frac{\text{mm}}{\text{inch}}$)

Standard warranty cover will be invalidated if the correct FlowVision monitoring head/control unit connecting cable is not used.

Description

Extended calorimetric monitoring head with variable immersion depth for Flow Meter FC01-LQ, suitable for use in pipes with process connections DN 50 plus.
Calibrated in water.

Caution: Fix with locking set 01 (see accessories).

Features

- Temperature range: -40 ... +130 °C/-40 ... +266 °F
- Material: stainless steel 1.4571/AISI 316 Ti

Ordering information

Type	CSF	Extended monitoring head with calorimetric sensors
	Monitoring head design	
	11	Monitoring head with variable immersion depth
	Medium	
	W	water
	Material of areas exposed to medium	
	M1	stainless steel 1.4571/AISI 316 Ti
	Process connection	
	00	without flange; see accessories for cable gland **)
	Length of shank/thread	
	L43	188 mm/7.40 in. (standard) other lengths upon request
	Electrical connection	
	E10	round connector with tinned contacts (plug and cable to order separately)
	Certification	
	T0	without certificate (standard *)
	Specification of medium	
	xxx	
CSF - 11 W M1 00 L43 E10 T0 - ... ordering example		

*) for detailed information please see section 0.
**) see next page.

Dimensions

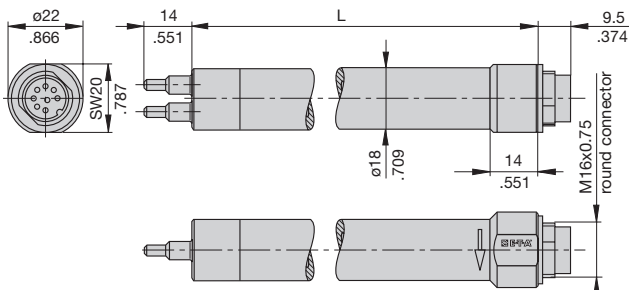

Type	L	
	mm	inch
CSF-...L43...	188	7.40
CSF-...L30...	300	11.81
CSF-...L40...	400	15.75

monitoring head should be aligned in direction of flow (see arrow)

This is a metric design and millimeter dimensions take precedence (mm/inch)

Monitoring head CSF

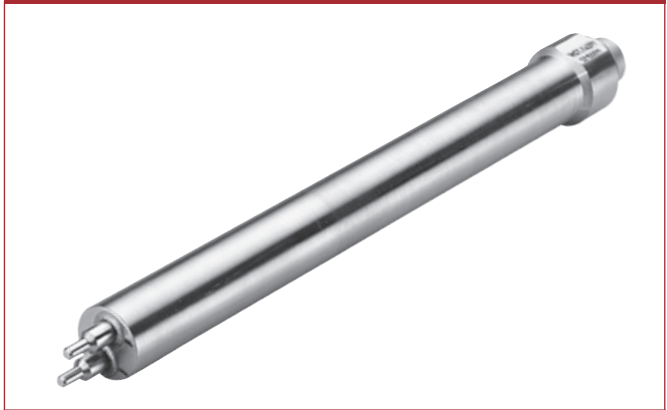

CSF-11
variable immersion depth

Technical data

Type of head	push-in
Nominal shank dia.	18 mm/.709 in. without thread
Length of shank	188 mm/7.40 in.
Length of sensor	14 mm/.551 in.
Suitable for	water (other liquids upon request)
Temperature range *)	-40 ... +130 °C/-40 ... +266 °F
(of medium)	
Temperature drift of monitoring head	± < 0.05 %/°C/measuring range ± < 0.09 %/°F/measuring range (T = +20 ... +80 °C/+68 ... +176 °F)
Measuring range	depending on immersion depth; max. velocity 3 m/s / 9.84 fps
Pressure resistance ⁽¹⁾	100 bar/1450 psi
(monitoring head)	
Pressure resistance ⁽¹⁾	depending on connection
(installation)	(see accessories)
Degree of protection ⁽²⁾	IP67
Material	stainless steel 1.457/AISI 316 Ti
Cable to electronic unit	LifYCY 4x2x0.2 mm ² (AWG 24)

⁽¹⁾ Admissible operating pressure DIN 2401, measured at max. temperature (= max. medium temperature)
⁽²⁾ with mating connector
^{*)} max. +85 °C/+185 °F in the connector area

Cable types 15/18 with connectors



Do + Ka type 15
Do + Ka type 18

Do + Ka type 15-ST
Do + Ka type 18-ST

Technical data

Cable type 15 and 15-ST

Features: highly flexible, paired, fully shielded, electrical and thermal properties at +20 °C/+68 °F

Conductor resistance:	92 Ω/km
Insulation resistance:	20 MΩ x km
Operating voltage:	250 V
Withstand voltage:	500 V
Max. load:	2 A
Temperature range:	-10 °C ... +80 °C/+14 °F ... +176 °F (processing and operation) -30 °C ... +80 °C/-22 ° F ... +176 °F (transport and storage)

Cable type 18 and 18-ST

Features: non-halogenous, highly flexible, cold- and heat resistant, paired, fully shielded, electrical and thermal properties at +20 °C/+68 °F

Conductor resistance:	80 Ω/km
Insulation resistance:	1200 MΩ x km
Operating voltage:	300 V
Withstand voltage:	1500 V
Max. load:	3 A
Temperature range:	-50 °C ... +180 °C/-58 °F ... +356 °F

Description

Cable between Flow Meter FC01-xxx and calorimetric monitoring head type CSF.

- Connection to monitoring head by means of 8-pole round connector
- Connection to FC01-xxx by means of 10-pole clamping connector (XSK)

1

Ordering information

Type between calorimetric monitoring heads **CSF** and **FC01-LQ, FC01-FH-LQ**

Do + Ka type 15	PVC insulated cable, type LifYCY 4x2x0,2 mm ² (AWG 24) 8-pole round connector + 10-pole clamping connector
Do + Ka type 18	silicone insulated cable, type 4x2x0,2mm ² (AWG 24) 8-pole round connector + 10-pole clamping connector

Available cable lengths

...m	2 m, 3 m, 5 m, 8 m, 10 m, 15 m, 20 m, 25 m, 30 m, 40 m, 50 m, 60 m, 70 m, 80 m, 90 m, 100 m, 110 m, 120 m, 130 m, 140 m, 150 m, 160 m, 170 m, 180 m, 190 m, 200 m (up to max 656 ft)
------	--

Do + Ka type 15 - 2 m/6.56 ft ordering example

Type between calorimetric monitoring heads **CSF** and **FC01-ST-LQ**

Do + Ka type 15-ST	PVC insulated cable, type LifYCY 4x2x0,2 mm ² (AWG 24) 8-pole round connector + 10-pole clamping connector
Do + Ka type 18-ST	silicone insulated cable, type 4x2x0,2mm ² (AWG 24) 8-pole round connector + 10-pole clamping connector

Available cable lengths

...m	2 m, 3 m, 5 m, 8 m, 10 m, 15 m, 20 m, 25 m, 30 m, 40 m, 50 m, 60 m, 70 m, 80 m, 90 m, 100 m, 110 m, 120 m, 130 m, 140 m, 150 m, 160 m, 170 m, 180 m, 190 m, 200 m (up to max 656 ft)
------	--

Do + Ka type 15-ST - 2 m/6.56 ft ordering example

Accessories

1

8-pole round connector
(without cable, for individual wiring by customer)
OZ112Z003124

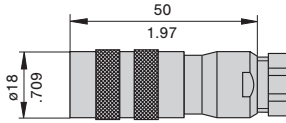

10-pole clamping connector for cable types 15 and 18
(without cable, for individual wiring by customer)
OZ112Z000167

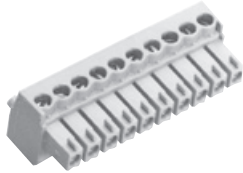

10-pole clamping connector for cable types 15-ST and 18-ST
(without cable, for individual wiring by customer)
OZ112Z000205



PG16 nickel-plated brass
(standard)
OZ122Z000128

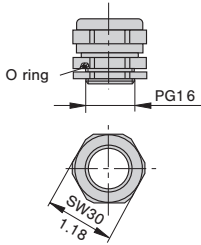

Pressure resistant up to 2 bar/29.0 psi

NPT3/4" moulded, black
OZ122Z000131

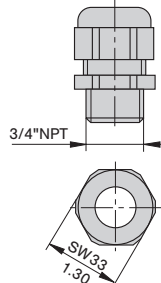

Pressure resistant up to 2 bar/29.0 psi

Threaded installation bush
OZ122Z000196

Teflon sealing ring
OZ122Z000197

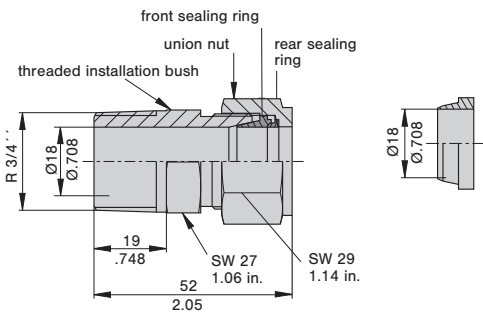

Suitable up to 25 bar/363 psi Pascal if used with stainless steel CSF-11 monitoring head.
(Observe instructions for installation)

Caution: Stainless steel ring is designed to cut into monitoring head.
Pressure resistant to 25 bar/363 psi.
Teflon ring can only be used from 0 to 2 bar/29.0 psi.

Please observe user manual!

Locking set 01
OZ122Z000204

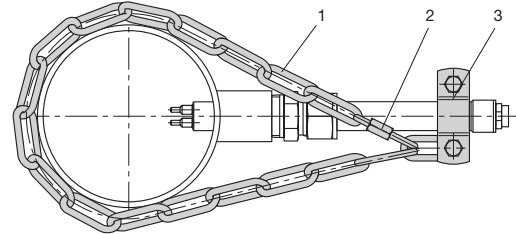

- 1 chain 4 x 32 DIN 5685 (approx. 1 m/3.28 ft)
- 2 catch for chain NG 5
- 3 clip with screw and nuts DN15 to DIN 11850

This is a metric design and millimeter dimensions take precedence ($\frac{\text{mm}}{\text{inch}}$)

Caution: Standard warranty cover will be invalidated if the correct FlowVision monitoring head/control unit connecting cable is not used.