

Description

Compact single point flow monitor, MIN or MAX monitoring options, suitable for water, oil, air or media with similar thermal conductivities.

Designed for use in

- ventilation systems with large pipe sizes (DN50 plus)
- cooling equipment with pipes with thick-walled insulation

If the flow rate falls below (MIN) or exceeds (MAX) the pre-adjusted value, the signal output will be switched and the yellow LED will light.

Features

- wear-resistant compact design, with stainless steel 1.4571 monitoring head and housing
- push-in type monitoring head
- switch point steplessly adjustable by means of potentiometer
- fault indication by yellow LED
- status indication by green LED
- media temperature range $-40^{\circ}\text{C} \dots +100^{\circ}\text{C} / -40^{\circ}\text{F} \dots +212^{\circ}\text{F}$
- M12 plug-in electrical connection
- signal output with HighSide-MOSFET output
- protected against short circuits and overloads



1

Connection diagram FS20

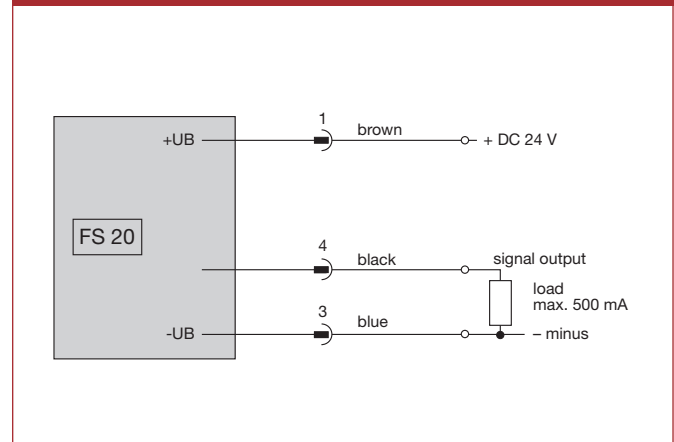

Ordering information

Flow monitor (calorimetric)									
FS20	compact flow monitor with variable push-in type monitoring head								
Power supply									
U1	DC 24 V								
Flow switch point									
MIN									
MAX									
Media									
A	air, gases								
W	water, oil, liquids								
Fitting material									
M1	stainless steel 1.4571								
Process connection									
00	without flange, threaded installation bush as accessory								
Length of shank									
L30	300 mm/11.8 in. (standard) other lengths upon request								
Electrical connection									
E12	M12x1, 3-pole								
Certification									
T0	without certificate *)								
FS10 - U1 MIN W - M1 00 L30 E12 T0	ordering example								

*) for detailed information please see section 0.

Electrical connection

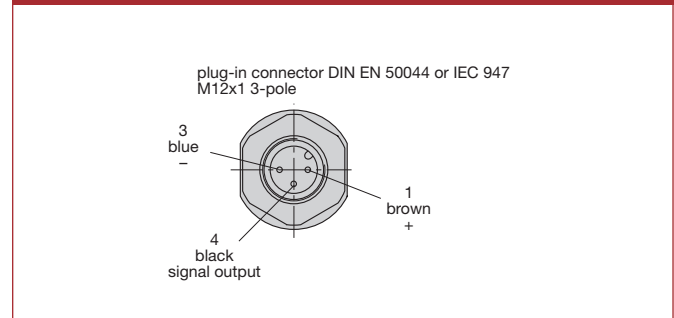

Flow rate ranges

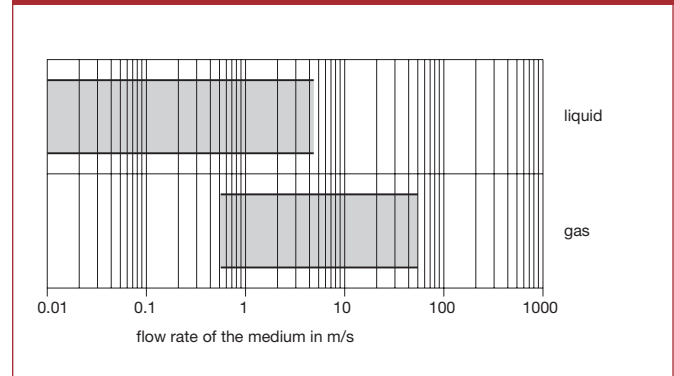

1

TECHNICAL DATA (ambient temperature $T_u = 25\text{ °C}/77\text{ °F}$, operating voltage $U_b = \text{DC } 24\text{ V}$)

General data		FS20
Suitable for		liquids, gases
Monitoring function	flow speed	switch point (min/max)
	fault indication	LED (yellow)
	signal output	Power MOSFET, High Side switch, short circuit proof
	max. load	500 mA, inductive load max. 100 mA
Temperature range	media	-40 °C ... +100 °C/-40 °F ... +212 °F
	ambience	-25 °C ... +80 °C/-13 °F ... +176 °F
Electrical data		
Operating voltage U_b		DC 24 V (18 ... 32 V)
Power consumption (without load)	gases	28 mA $\pm 5\%$
	liquids	57 mA $\pm 3\%$
Status indication		LED (green)
Connection to DIN 50044		M 12x1 plug-in connection, 3-pole
Flow monitoring		
Flow response level adjustment	air	0,5 ... 50 m/s / 1.64 ... 164 fps (atmospheric pressure)
	water, oil	0,01 ... 4,5 m/s / 0.0328 ... 14.8 fps
Repeatability ⁽¹⁾		$\leq \pm 3\%$
Response delay	water	typ. 2 s ⁽²⁾
	air	typ. 8 s ⁽³⁾
	oil	typ. 5 s ⁽²⁾
Switch point drift because of temperature change of the medium		approx. $\pm 1,0\%/^{\circ}\text{C}$ / $\pm 1,8\%/^{\circ}\text{F}$
Mechanical data (push-in type monitoring head)		
Type of monitoring head		push-in
Diameter of shank		18 mm/0.709 in. without thread
Length of shank		300 mm/11.8 in. (standard)
Length of sensor		14 mm/0.551 in.
Suitable for		liquids, gases
Temperature range (of liquids/gases) *)		-40 °C ... +100 °C/-40 °F ... +212 °F
Pressure resistance of sensor ⁽⁴⁾		100 bar/1450 psi/stainless steel
Pressure resistance when installed with threaded installation bush		25 bar/363 psi
Degree of protection		IP68 (connector, only if plugged in)
Materials (standard)	fitting (wetted)	stainless steel 1.4571
	sensor (wetted)	stainless steel 1.4571
	connection sensor/fitting	laser welded
	housing	stainless steel 1.4571
	M12 connector	CuZn, nickel-plated
	cap	PA (transparent)
	O-ring	Viton (FPM)
Weight		approx. 740 g/1.63 lb
⁽¹⁾ of the set value, at constant temperature and flow conditions, and stable thermal conductivity ⁽²⁾ delay with the switch point set to 1 m/s / 3.28 fps and the flow at 2 m/s / 6.56 fps, after a sudden complete stop ⁽³⁾ delay with the switch point set to 10 m/s / 32.8 fps and the flow at 20 m/s / 65.6 fps, after a sudden complete stop ⁽⁴⁾ admissible operating pressure DIN 2401, measured at max. temperature (= max. medium temperature) *) max. 80 °C in the connector area		

Dimensions (standard length)

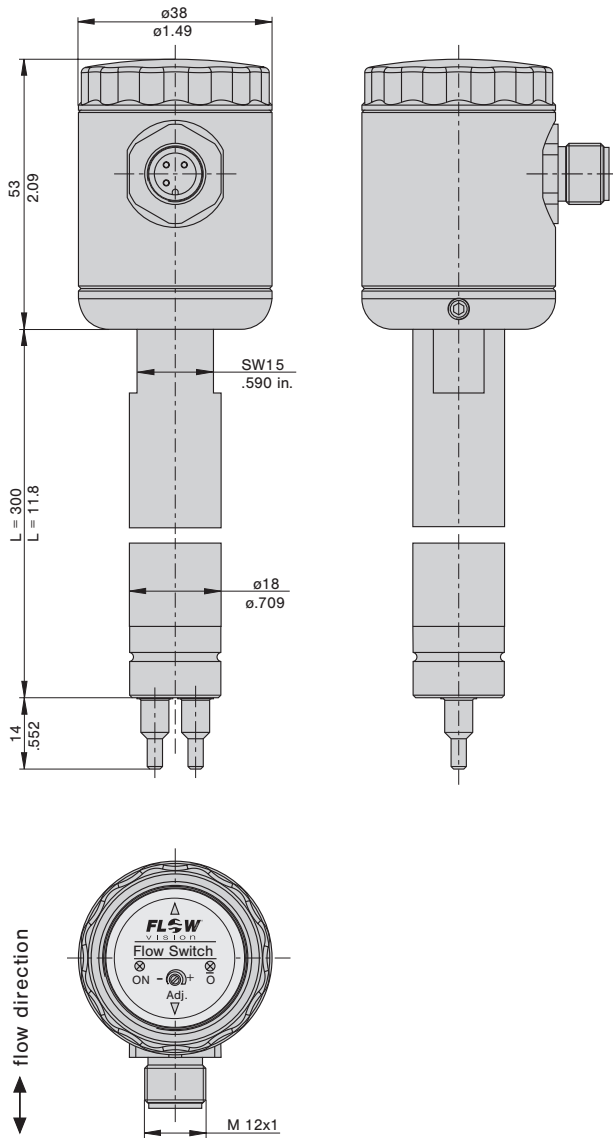

This is a metric design and millimeter dimensions take precedence ($\frac{mm}{inch}$)

Accessories

Threaded installation bush
OZ122Z000196

Teflon sealing ring
OZ122Z000197

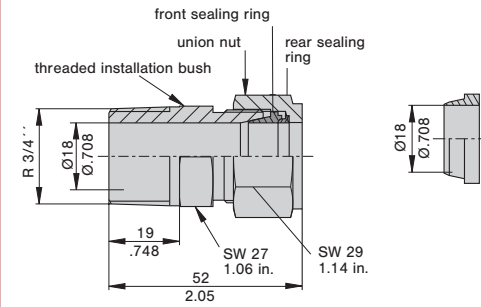

Suitable up to 25 bar/2.5 MPa/363 psi if used with stainless steel MK monitoring head. (Observe instructions for installation.)

Caution: Stainless steel ring is designed to cut into monitoring head. Pressure resistant to 25 bar/2.5 MPa/363 psi. Teflon ring can only be used from 0 to 2 bar/0.2 MPa/29 psi.

Please observe user manual and safety guidelines!

Locking set 01
OZ122Z000204

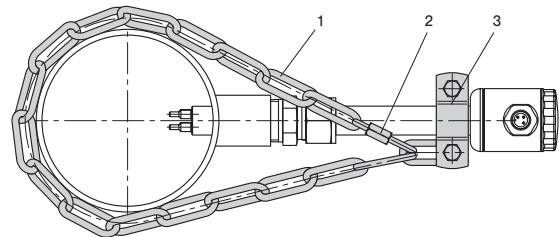

- 1 chain 4 x 32 DIN 5685 (approx. 1 m/3.28 ft)
- 2 catch for chain NG 5
- 3 clip with screw and nuts DN15 to DIN 11850

All dimensions without tolerances are for reference only. In the interest of improved design, performance and cost effectiveness the right to make changes in these specifications without notice is reserved. Product markings may not be exactly as the ordering codes. Errors and omissions excepted.

Cable type 24 with connectors



Description

M12 plug-in electrical connection for connection of supply voltage and switching output.

Technical data

Cable type 24

Features: Protection degree IP67 (only with connector fitted)
Resistant to chemicals and oils

Temperature range: -25 °C ... +80 °C / -13 °F ... +176 °F

Contact resistance: ≤ 5 mΩ

Current carrying capacity: 4 A

Insulation resistance: > 10⁹ Ω

Withstand voltage: 2.0 kV_{eff} / 60 s

Ordering information

Cable and cable connector

Do + Ka type 24 - 5 m with connector to IEC60947-5-2, 3-pole
M12 and PUR insulated cable 3x0.34 mm² /
3x5.27 · 10⁻⁴ in.² (AWG 22), halogen-free

Do + Ka type 24 - 5 m ordering example